

# CTG SM H450 1200x700 RIF. MOD. 3

800312070100

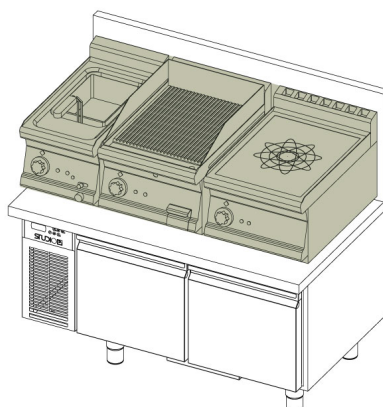

## DIMENSIONS AND WEIGHTS

External dimensions in mm. ( LxPxH ): 1200x700x640

Net/gross weight in Kg.: 60/82

Through-in door dimensions in mm. (LxP): 362x332

Capacity ( Liters ): 110

Packaging dimensions in mm. (LxPxH): 1370x750x1100

Insulation thickness: 60mm

## TECHNICAL FEATURES

Voltage: 230V / 50Hz / 1

Freon : R290

Defrosting: Automatic

Electronic temperature control device: Yes

Condensation discharge: Automatic

Absorption ( W ): 249W / 2,34A

Construction materials: External/internal body made in certified AISI 304 stainless steel

Out put:

EVAPORATION RESISTANCE: /

DEFROSTING RESISTANCE: /

LIGHTING ABSORPTION: /

Refrigerant charge Kg: 0,120

tCO2e:

## GENERAL FEATURES

Working temperature: 0°/+8°C

Refrigeration system : Air forced

Built-in motor: Yes

On castors: On demand

Lighting: No

Door with magnetic seal: Yes

Doors with return: Yes

## ENERGETIC FEATURES

Climate class: 5 (40°C - 40%)

Refrigeration Volume Vnref (L): 103

Freezing Volume Vnfrz (L): -

Typology: Horizontal Cabinet

Daily power consumption E24 h: 1,20

Annual absorption AEC KWh/Annum: 438

Performance: High performance - This appliance is intended for use in ambient temperatures up to 40 ° C

Category: Storage

## STUDIO 54 SRL

Via Gian Lorenzo Bernini 147 - 35010 San Giorgio in Bosco PD  
 T +39 049 9450466 - F +39 0499451044 - Cod. fiscale e p.iva 00096970280 - R.E.A. n. 247856  
 www.studio-54.it info@studio-54.it

## TECHNICAL DESIGN

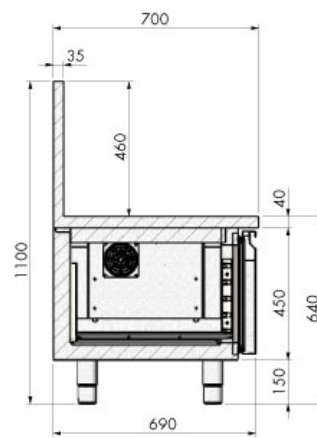
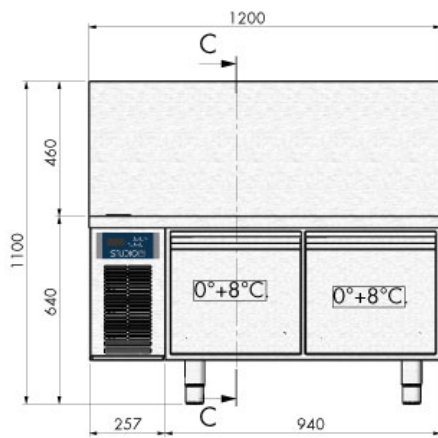

SEZIONE C-C

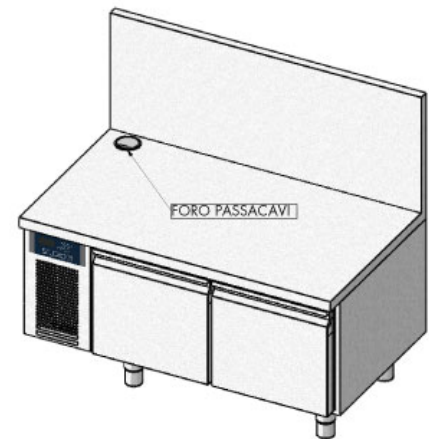
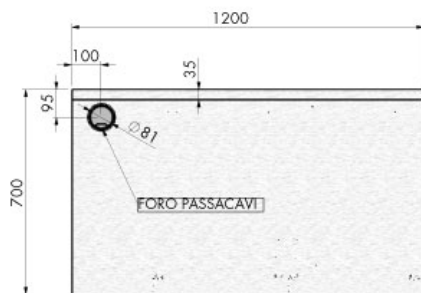

**STUDIO-54 S.r.l.**  
Via Gian Lorenzo Bernini 147, 35010 San Giorgio in Bosco (PD)  
T. +39 049 9450466 - F. +39 049 9451044 - C.F e P.I. 00096970280 - R.E.A. n.247856  
[www.studio-54.it](http://www.studio-54.it) [info@studio-54.it](mailto:info@studio-54.it)

## OPTIONAL

### STUDIO 54 SRL

Via Gian Lorenzo Bernini 147 - 35010 San Giorgio in Bosco PD  
T +39 049 9450466 - F +39 0499451044 - Cod. fiscale e p.iva 00096970280 - R.E.A. n. 247856  
[www.studio-54.it](http://www.studio-54.it) [info@studio-54.it](mailto:info@studio-54.it)