

# CTG SM H760 1160x700 RIF. MOD. 1

800111670700

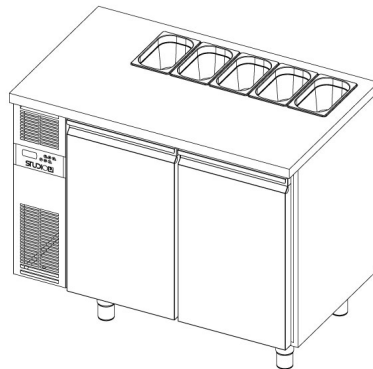

## DIMENSIONS AND WEIGHTS

External dimensions in mm. ( LxPxH ):	1160x700x950
Net/gross weight in Kg.:	107/130
Through-in door dimensions in mm. (LxP):	642x362
Capacity ( Liters ):	210
Packaging dimensions in mm. (LxPxH):	1370x750x1100
Insulation thickness:	60mm

## TECHNICAL FEATURES

Voltage:	230V / 50Hz / 1
Freon :	R290
Defrosting:	Automatic
Electronic temperature control device:	Yes
Condensation discharge:	Automatic
Absorption ( W ):	210W / 1,32A
Construction materials:	External/internal body made in certified AISI 304 stainless steel
Out put:	341 W
EVAPORATION RESISTANCE:	/
DEFROSTING RESISTANCE:	/
LIGHTING ABSORPTION:	/
Refrigerant charge Kg:	/

## GENERAL FEATURES

Working temperature:	0°/+8°C
Refrigeration system :	Air forced
Built-in motor:	Yes
On castors:	On demand
Lighting:	No
Door with magnetic seal:	Yes
Doors with return:	Yes

## ENERGETIC FEATURES

Climate class:	5 (40°C - 40%)
Refrigeration Volume Vnref (L):	/
Freezing Volume Vnfrz (L):	-
Typology:	/
Daily power consumption E24 h:	/
Annual absorption AEC KWh/Annum:	/
Performance:	/
Category:	/

## STUDIO 54 SRL

Via Gian Lorenzo Bernini 147 - 35010 San Giorgio in Bosco PD  
 T +39 049 9450466 - F +39 0499451044 - Cod. fiscale e p.iva 00096970280 - R.E.A. n. 247856  
 www.studio-54.it info@studio-54.it

## TECHNICAL DESIGN

## OPTIONAL

### STUDIO 54 SRL

Via Gian Lorenzo Bernini 147 - 35010 San Giorgio in Bosco PD  
T +39 049 9450466 - F +39 0499451044 - Cod. fiscale e p.iva 00096970280 - R.E.A. n. 247856  
[www.studio-54.it](http://www.studio-54.it) [info@studio-54.it](mailto:info@studio-54.it)